

SERIES INFORMATION  
CANNED MOTOR PUMP TYPE CAM / CAMR

# REFRIGERATION ENGINEERING

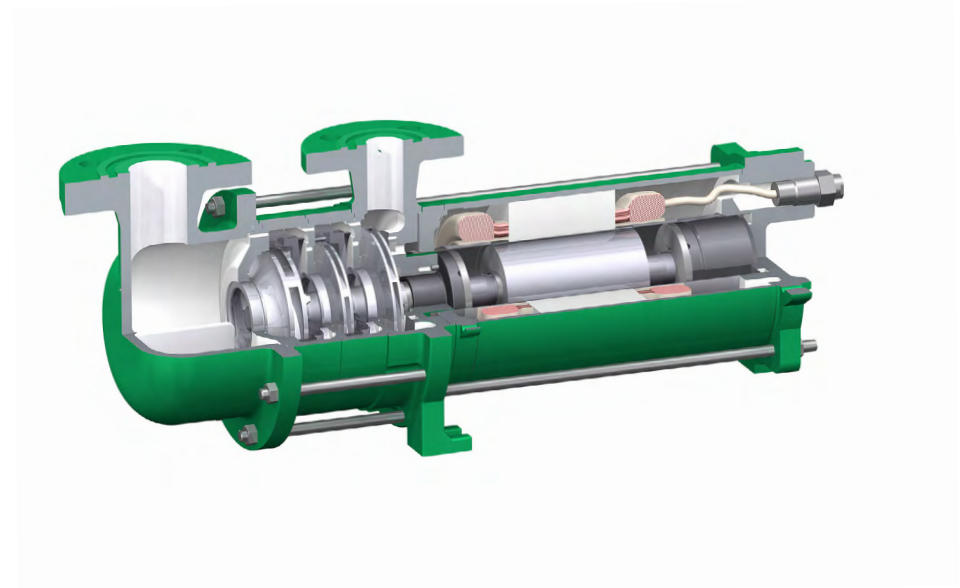
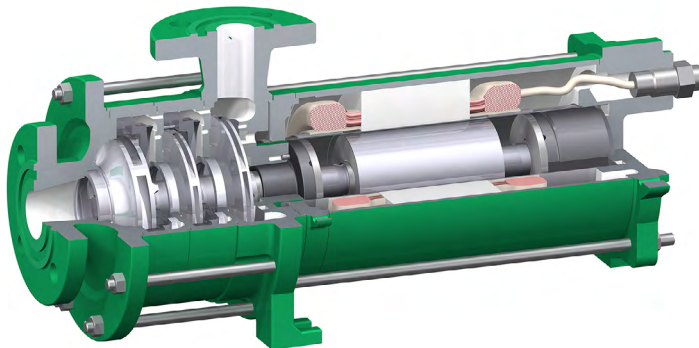

**Information**

---

**Operating data**

**Temperature**

Areas of application -50 °C to +30 °C

**Canned motors**

Output	up to 25.0 kW
Speed	2800 rpm or 3500 rpm (frequency control possible – with frequency converter from 1500 rpm to 3500 rpm)
Voltage	230, 400, 480, 500, 575, 690 Volt
Frequency	50 Hz or 60 Hz
Type of protection	IP 55

**Pump and hydraulics designations**

**CAM 2 / 3 AGX 3.0**

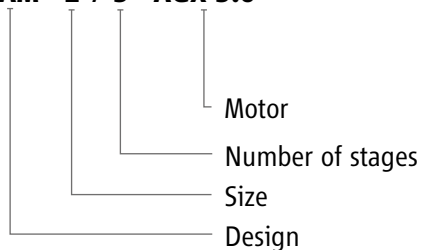

Table of Contents

**General information**

Function

Operating principle

Characteristic maps

Versions

CAM 1 / CAM 2

CAMR 2

CAM 3

Documentation and tests

Installation

Protection and monitoring

Flow regulation

Design software

Contact



**CAM function**

The partial flow for cooling the motor and lubricating the bearing is taken from the pressure side after the last impeller and passed through the motor chamber. The partial flow is not returned to the suction side of the pump through the hollow shaft but to an area with increased pressure between two impellers. Therefore, point 3 in the pressure-temperature diagram that corresponds to the greatest heating has sufficient distance from the vapour pressure curve to prevent gasification within the pump.

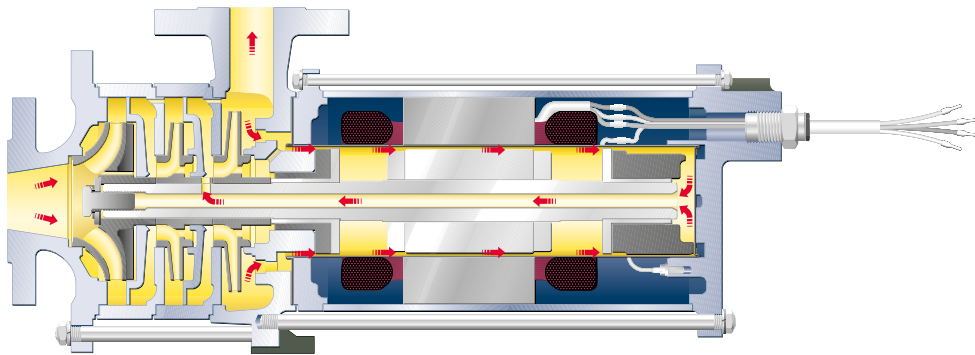

Partial flow return between the stages

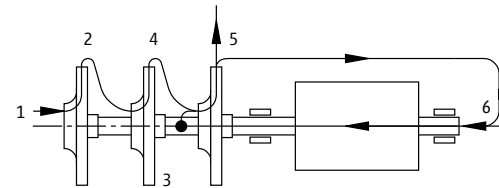

Pressure-temperature diagram

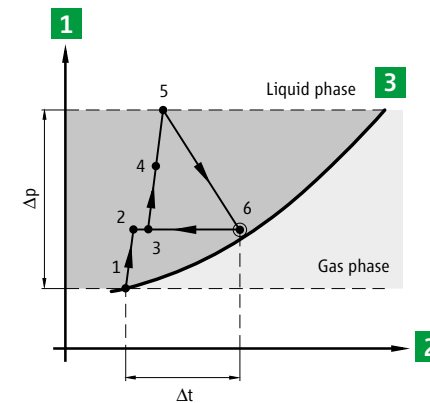

- 1 Pressure
- 2 Temperature
- 3 Vapour pressure curve

Table of Contents

General information

**Function**

Operating principle

Characteristic maps

Versions

CAM 1 / CAM 2

CAMR 2

CAM 3

Documentation and tests

Installation

Protection and monitoring

Flow regulation

Design software

Contact



2900 rpm 50 Hz

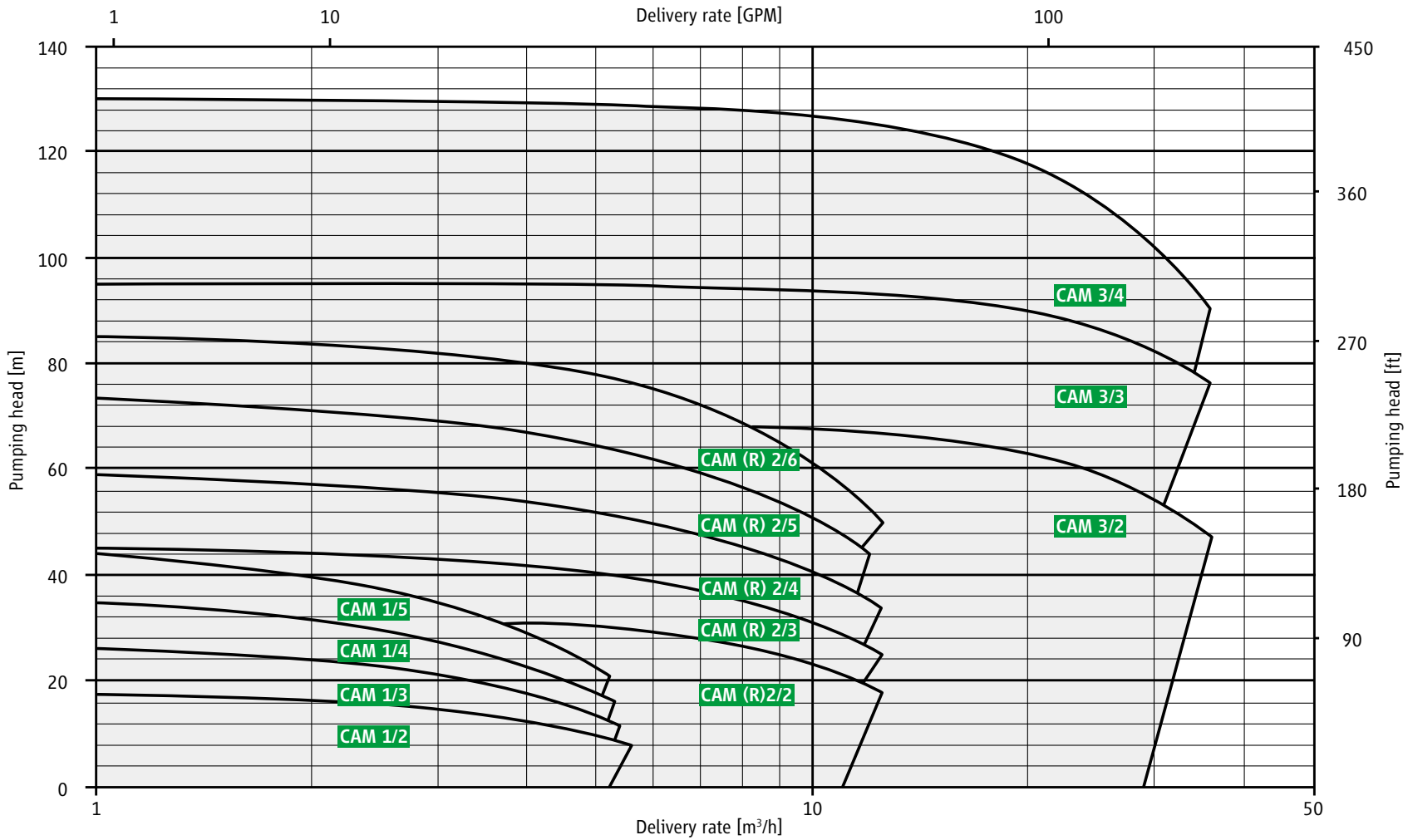

- Table of Contents
- General information
- Function
- Operating principle
- Characteristic maps**
- Versions
- CAM 1 / CAM 2
- CAM R 2
- CAM 3
- Documentation and tests
- Installation
- Protection and monitoring
- Flow regulation
- Design software
- Contact



3500 rpm 60 Hz

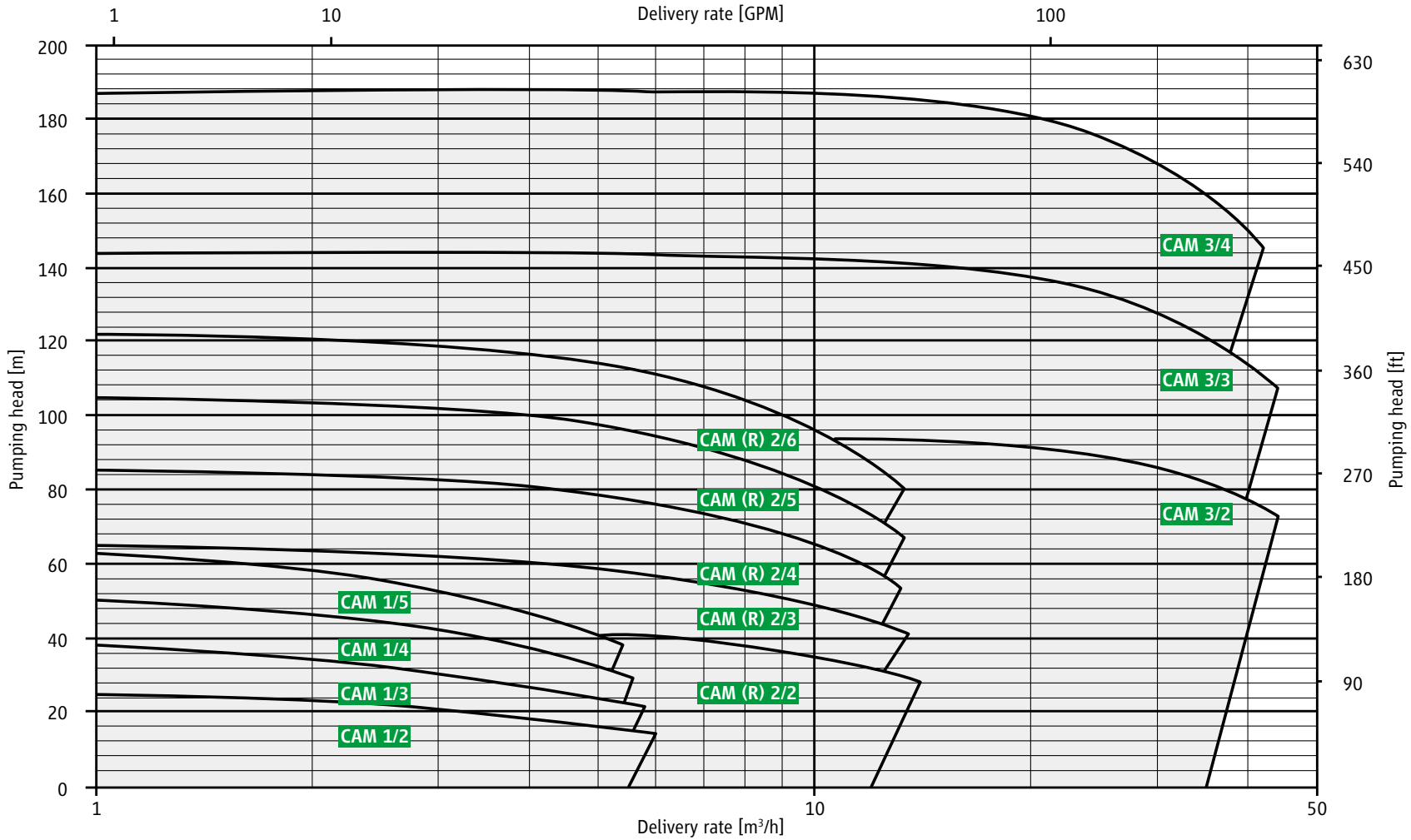

- Table of Contents
- General information
- Function
- Operating principle
- Characteristic maps**
- Versions
- CAM 1 / CAM 2
- CAM R 2
- CAM 3
- Documentation and tests
- Installation
- Protection and monitoring
- Flow regulation
- Design software
- Contact



## Versions CAM / CAMR

Type	Motor	Pump data		Motor data 50 Hz / 60 Hz		Weight kg	PN
		Q <sub>min</sub> m <sup>3</sup> /h	Q <sub>max</sub> m <sup>3</sup> /h	Output kW [P2]	Rated current at 400 V / 480 V		
CAM 1/2	AGX 1.0	0.5	5.0	1.0 / 1.2	2.7	27.0	40
CAM 1/3	AGX 1.0	0.5	5.0	1.0 / 1.2	2.7	28.0	40
CAM 1/4	AGX 1.0	0.5	5.0	1.0 / 1.2	2.7	29.0	40
CAM 1/5	AGX 1.0	0.5	5.0	1.0 / 1.2	2.7	30.0	40
CAM (R) 2/2	AGX 3.0	1.0	13.0	3.0 / 3.4	7.1	48.0	40
CAM (R) 2/2	AGX 4.5	1.0	14.0	4.5 / 5.6	10.4	56.0	40
CAM (R) 2/3	AGX 3.0	1.0	13.0	3.0 / 3.4	7.1	52.0	40
CAM (R) 2/3	AGX 4.5	1.0	14.0	4.5 / 5.6	10.4	60.0	40
CAM (R) 2/3	AGX 6.5	1.0	14.0	6.5 / 7.5	15.2	63.0	40
CAM (R) 2/4	AGX 3.0	1.0	14.0	3.0 / 3.4	7.1	56.0	40
CAM (R) 2/4	AGX 4.5	1.0	14.0	4.5 / 5.6	10.4	68.0	40
CAM (R) 2/4	AGX 6.5	1.0	14.0	6.5 / 7.5	15.2	71.0	40
CAM (R) 2/5	AGX 3.0	1.0	14.0	3.0 / 3.4	7.1	60.0	40
CAM (R) 2/5	AGX 4.5	1.0	14.0	4.5 / 5.6	10.4	74.0	40
CAM (R) 2/5	AGX 6.5	1.0	14.0	6.5 / 7.5	15.2	77.0	40
<b>CAM (R) 2/6</b>	<b>AGX 3.0</b>	<b>1.0</b>	<b>14.0</b>	<b>3.0 / 3.4</b>	<b>7.1</b>	<b>64.0</b>	<b>40</b>
CAM (R) 2/6	AGX 4.5	1.0	14.0	4.5 / 5.6	10.4	78.0	40
CAM (R) 2/6	AGX 6.5	1.0	14.0	6.5 / 7.5	15.2	81.0	40
CAM 3/2	AGX 8.5	6.0	30.0	8.5 / 9.7	19.0	120.0	40
CAM 3/2	CKPx 12.0	6.0	30.0	13.5 / 15.7	31.0	150.0	25 / 40
CAM 3/3	AGX 8.5	6.0	30.0	8.5 / 9.7	19.0	138.0	40
CAM 3/3	CKPx 12.0	6.0	30.0	13.5 / 15.7	31.0	168.0	25 / 40
CAM 3/3	CKPx 19.0	6.0	30.0	22.0 / 25.0	49.5	213.0	25 / 40
CAM 3/4	CKPx 12.0	6.0	35.0	13.5 / 15.7	31.0	186.0	25 / 40
CAM 3/4	CKPx 19.0	6.0	35.0	22.0 / 25.0	49.5	231.0	25 / 40

[Table of Contents](#)[General information](#)[Function](#)[Operating principle](#)[Characteristic maps](#)[Versions](#)[CAM 1 / CAM 2](#)[CAMR 2](#)[CAM 3](#)[Documentation and tests](#)[Installation](#)[Protection and monitoring](#)[Flow regulation](#)[Design software](#)[Contact](#)

## Materials / pressure stages / flanges

Housing	JS 1025
Suction cover (suction housing CAMR 2)	JS 1025
Stage casing (CAM 1, CAM 2, CAMR 2)	1.0460
Stage casing (CAM 3)	JS 1025
Diffuser (guide wheel CAM 3)	JL 1030
Impellers	JL 1030
Slide bearing	1.4021 / carbon
Shaft	1.4021
Rotor lining	1.4571
Seals	AFM 34*
Pressure rating	PN 40**, PN 25 (for motors CKPx 12.0 and CKPx 19.0)
Flanges	according to DIN EN 1092-1, PN 40 and PN 25 type D

\* asbestos-free aramid fibre, \*\* test pressure 60 bar

## Noise expectancy values

Motors	AGX 1.0	AGX 3.0	AGX 4.5	AGX 6.5	AGX 8.5	CKPx 12.0	CKPx 19.0
Output power [P2 at 50 Hz]	1.0 kW	3.0 kW	4.5 kW	6.5 kW	8.5 kW	13.5 kW	22.0 kW
max. expected sound pressure level dB(A) at 50 Hz	48	52	54	56	57	59	61
Output power [P2 at 60 Hz]	1.2 kW	3.4 kW	5.6 kW	7.5 kW	9.7 kW	15.7 kW	25.0 kW
max. expected sound pressure level dB(A) at 60 Hz	48	52	55	56	57	59	61

Table of Contents

General information

Function

Operating principle

Characteristic maps

Versions

CAM 1 / CAM 2

CAMR 2

CAM 3

Documentation and tests

Installation

Protection and monitoring

Flow regulation

Design software

Contact



List of parts CAM 1 / CAM 2

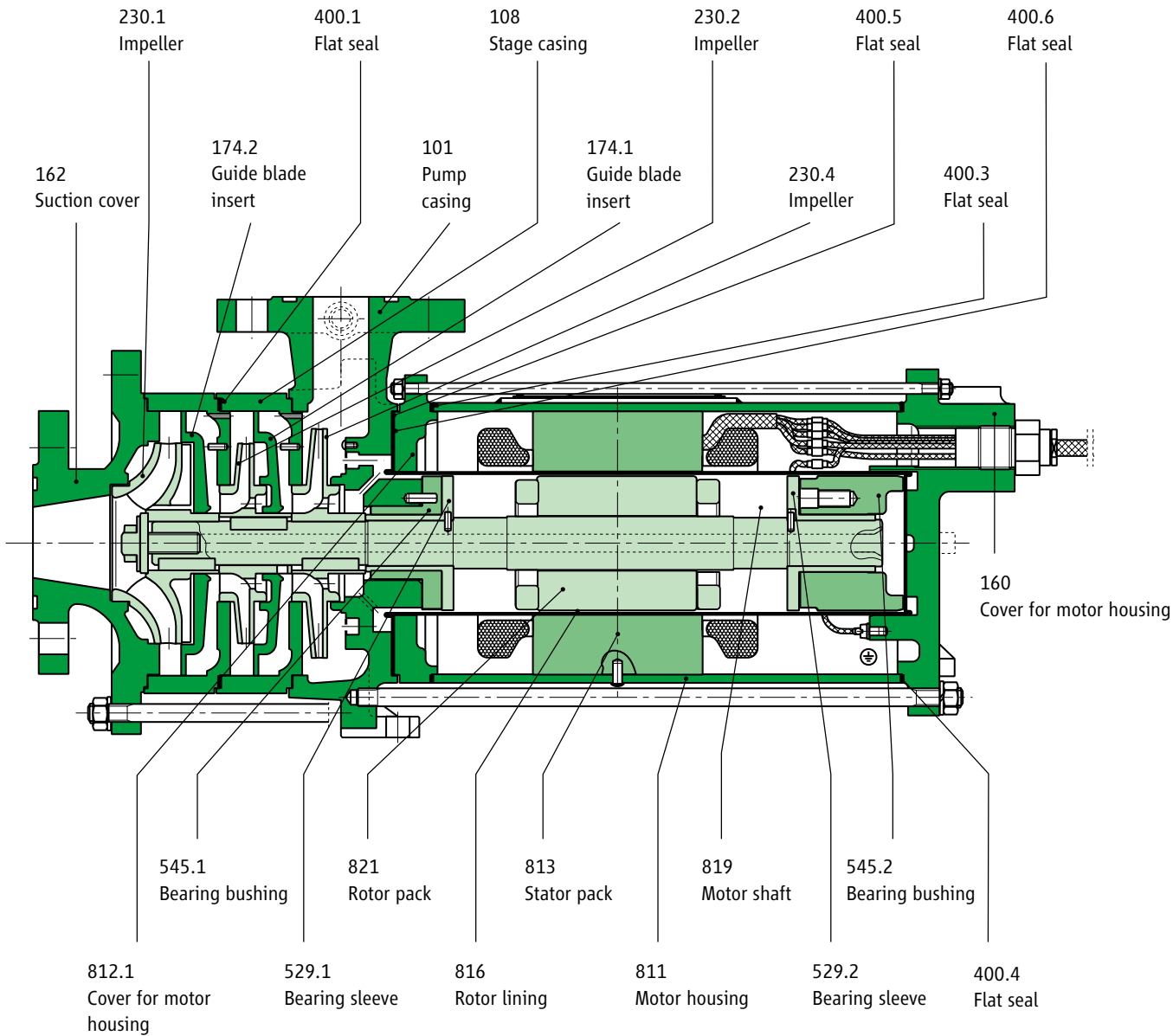

- Table of Contents
- General information
- Function
- Operating principle
- Characteristic maps
- Versions
- CAM 1 / CAM 2**
- CAMR 2
- CAM 3
- Documentation and tests
- Installation
- Protection and monitoring
- Flow regulation
- Design software
- Contact



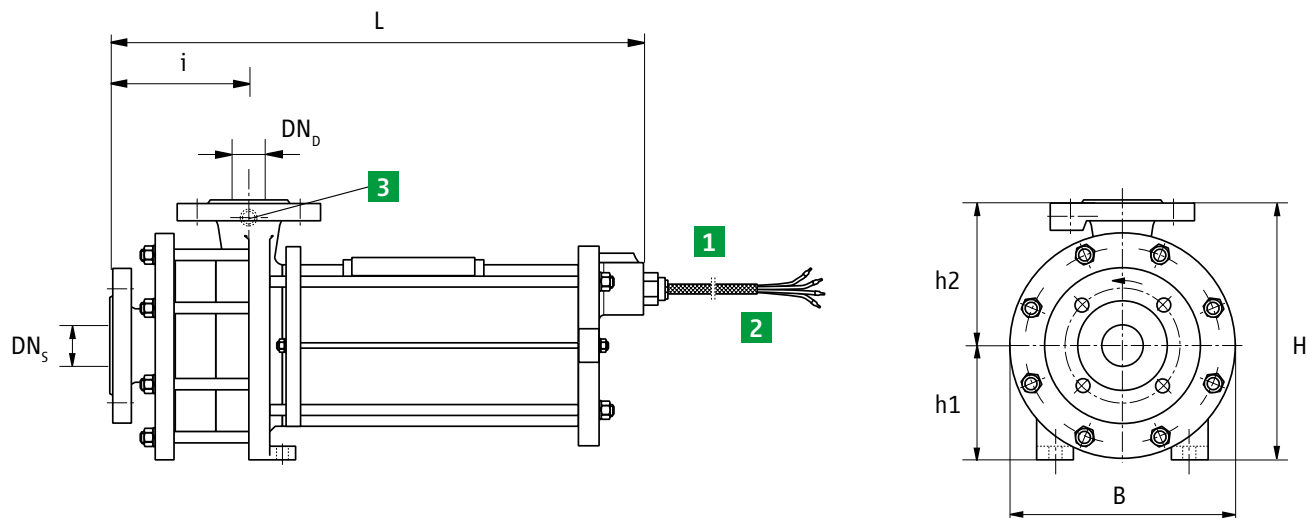

**Dimension drawing for motors of size: AGX 1.0 / AGX 3.0 / AGX 4.5 / AGX 6.5**

- |   |  |
|---|--|
| <b>1</b> Cable U1, V1, W1 + protective conductor $\oplus$ | <b>2</b> Cable for PTC thermistor        |
| AGX 1.0: 4 x 1.5 mm <sup>2</sup>                          | 2 x 1.0 mm <sup>2</sup> , cable 5 + 6,   |
| AGX 3.0: 4 x 1.5 mm <sup>2</sup>                          | Cable length 2.5 m                       |
| AGX 4.5: 4 x 2.5 mm <sup>2</sup>                          | <b>3</b> Pressure gauge connection G 1/4 |
| AGX 6.5: 4 x 4 mm <sup>2</sup>                            |  |
| Cable length 2.5 m  |  |

[Table of Contents](#)
[General information](#)
[Function](#)
[Operating principle](#)
[Characteristic maps](#)
[Versions](#)
[CAM 1 / CAM 2](#)
[CAMR 2](#)
[CAM 3](#)
[Documentation and tests](#)
[Installation](#)
[Protection and monitoring](#)
[Flow regulation](#)
[Design software](#)
[Contact](#)

## Versions CAM 1

Dimensions	CAM 1 / 2-stage	CAM 1 / 3-stage	CAM 1 / 4-stage	CAM 1 / 5-stage
	AGX 1.0	AGX 1.0	AGX 1.0	AGX 1.0
Length / L	419	447	475	503
Width / W	160	160	160	160
Height / H	10	210	210	210
h1	90	90	90	90
h2	120	120	120	120
i	112	140	168	196
DN <sub>s</sub>	25	25	25	25
DN <sub>b</sub>	20	20	20	20

## Versions CAM 2

Dimensions	CAM 2 / 2-stage	CAM 2 / 3-stage	CAM 2 / 4-stage	CAM 2 / 5-stage	CAM 2 / 6-stage
	AGX 3.0 / 4.5	AGX 3.0 to 6.5	AGX 3.0 to 6.5	AGX 3.0 to 6.5	AGX 3.0 to 6.5
Length / L	536	577	618	659	700
Width / W	218	218	218	218	218
Height / H	250	250	250	250	250
h1	110	110	110	110	110
h2	140	140	140	140	140
i	135	176	217	258	299
DN <sub>s</sub>	40	40	40	40	40
DN <sub>b</sub>	32	32	32	32	32

Table of Contents

General information

Function

Operating principle

Characteristic maps

Versions

**CAM 1 / CAM 2**

CAMR 2

CAM 3

Documentation and tests

Installation

Protection and monitoring

Flow regulation

Design software

Contact



List of parts CAMR 2

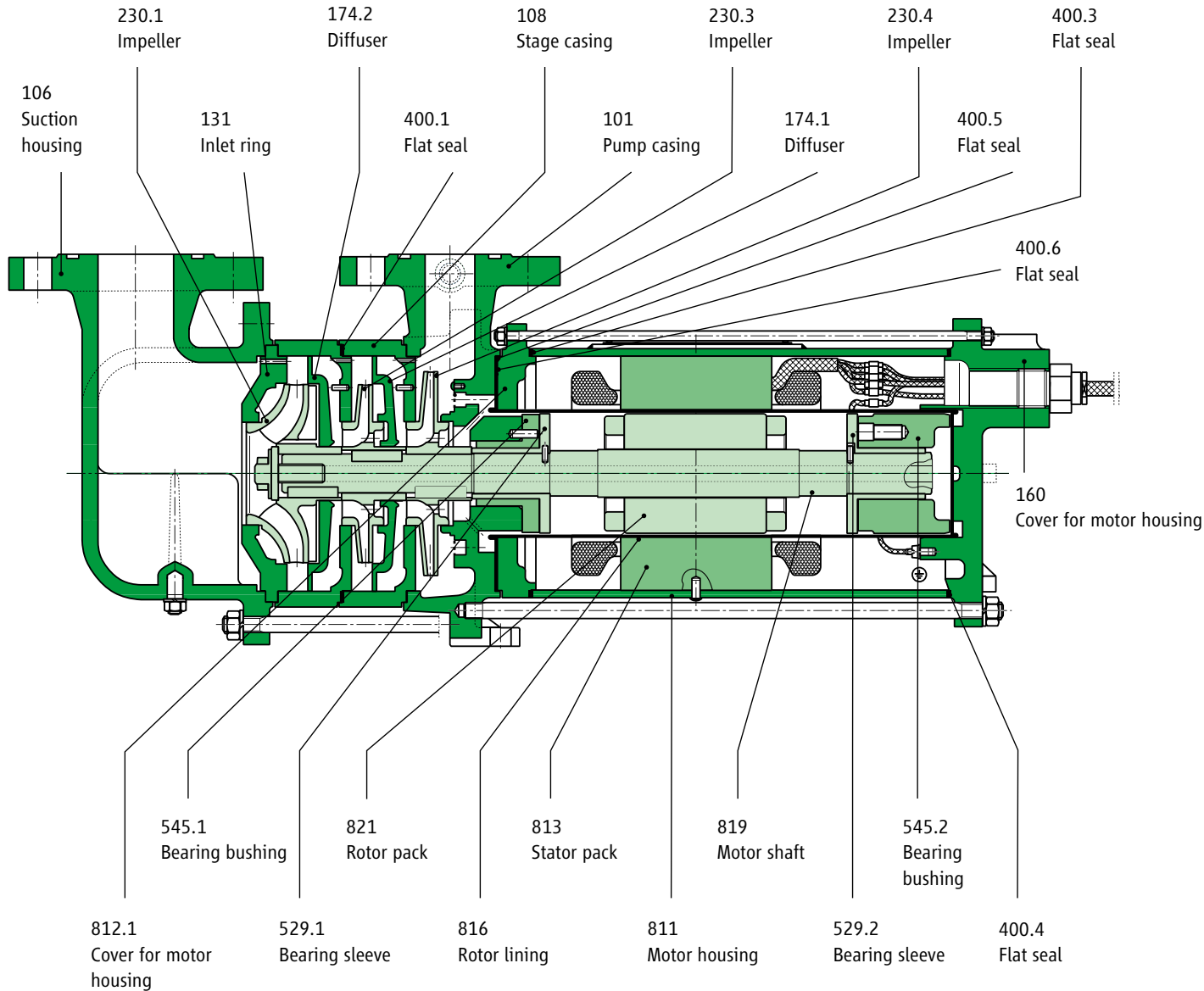

- Table of Contents
- General information
- Function
- Operating principle
- Characteristic maps
- Versions
- CAM 1 / CAM 2
- CAMR 2**
- CAM 3
- Documentation and tests
- Installation
- Protection and monitoring
- Flow regulation
- Design software
- Contact

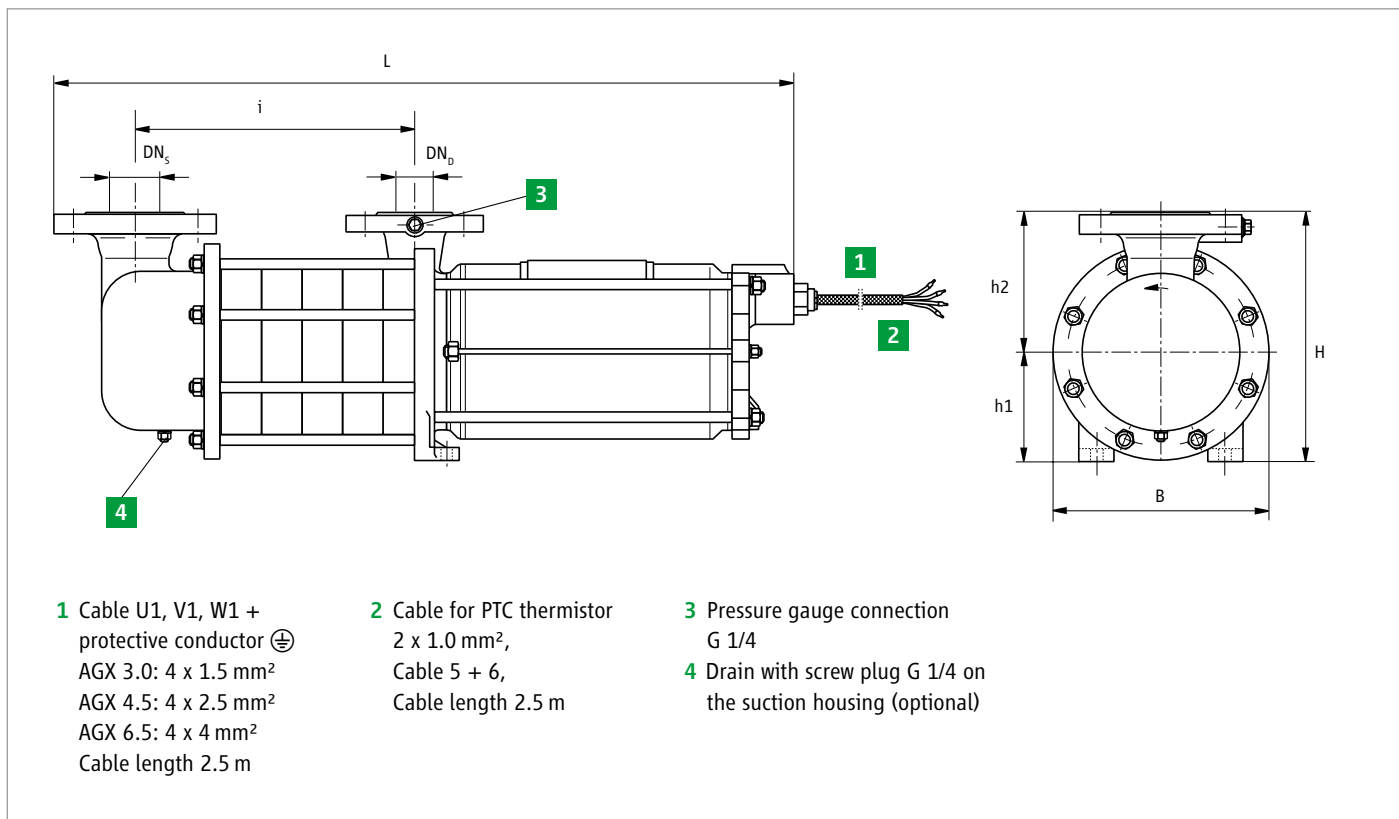

**Dimension drawing for motors of size: AGX 3.0 / AGX 4.5 / AGX 6.5**

[Table of Contents](#)
[General information](#)
[Function](#)
[Operating principle](#)
[Characteristic maps](#)
[Versions](#)
[CAM 1 / CAM 2](#)
**[CAMR 2](#)**
[CAM 3](#)
[Documentation and tests](#)
[Installation](#)
[Protection and monitoring](#)
[Flow regulation](#)
[Design software](#)
[Contact](#)

## Versions CAMR 2

Dimensions	CAMR 2 / 2-stage	CAMR 2 / 3-stage	CAMR 2 / 4-stage	CAMR 2 / 5-stage	CAMR 2 / 6-stage
	AGX 3.0 / 4.5	AGX 3.0 to 6.5	AGX 3.0 to 6.5	AGX 3.0 to 6.5	AGX 3.0 to 6.5
Length / L	649	690	731	772	813
Width / W	218	218	218	218	218
Height / H	250	250	250	250	250
h1	110	110	110	110	110
h2	140	140	140	140	140
i	160	201	242	283	324
DN <sub>s</sub>	50	50	50	50	50
DN <sub>b</sub>	32	32	32	32	32

Table of Contents

General information

Function

Operating principle

Characteristic maps

Versions

CAM 1 / CAM 2

**CAMR 2**

CAM 3

Documentation and tests

Installation

Protection and monitoring

Flow regulation

Design software

Contact

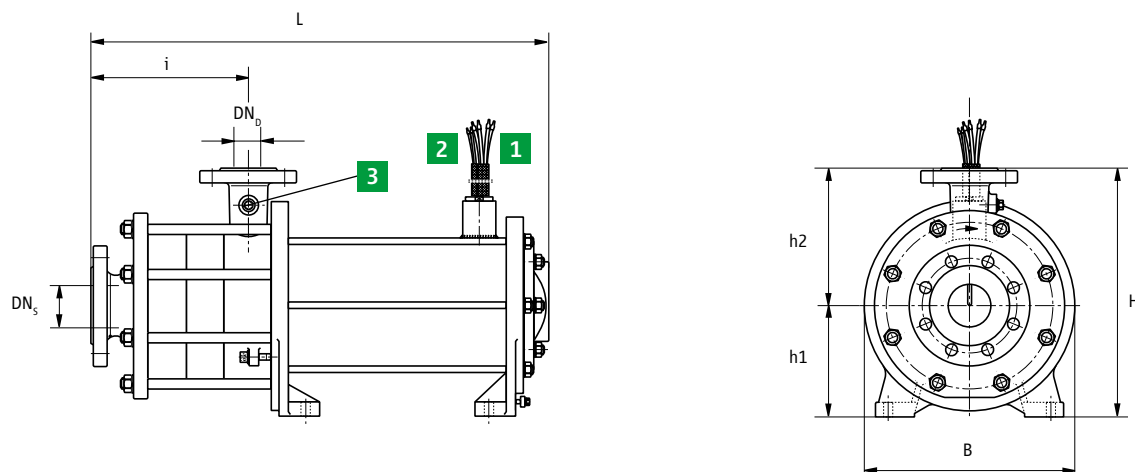

**Dimension drawing for motors of size: AGX 8.5 / CKPx 12.0 / CKPx 19.0**

- |  |  |   |
|--|--|---|
| <p><b>1</b> Cable U1, V1, W1 + protective conductor ⊕<br/>           AGX 8.5: 4 x 6 mm<sup>2</sup><br/>           CKPx 12.0: 4 x 6 mm<sup>2</sup><br/>           CKPx 19.0: 4 x 6 mm<sup>2</sup><br/>           Cable length 2.5 m</p> | <p><b>2</b> Cable for PTC thermistor<br/>           2 x 1.0 mm<sup>2</sup>, cable 5 + 6,<br/>           Cable length 2.5 m</p> | <p><b>3</b> Pressure gauge connection G 1/4</p> |
|--|--|---|

[Table of Contents](#)
[General information](#)
[Function](#)
[Operating principle](#)
[Characteristic maps](#)
[Versions](#)
[CAM 1 / CAM 2](#)
[CAMR 2](#)
**[CAM 3](#)**
[Documentation and tests](#)
[Installation](#)
[Protection and monitoring](#)
[Flow regulation](#)
[Design software](#)
[Contact](#)

### Automatic venting

1. Use a non-return valve between the discharge nozzle and gate valve to ensure that the medium does not flow back after switching off the pump.
2. To allow venting, provide a bypass pipe:
  - Ahead of the non-return valve.
  - Please note: do not provide non-return valves in the bypass pipe.
3. For parallel operation:
  - Separate supplies for the pumps
  - Separate bypass pipes

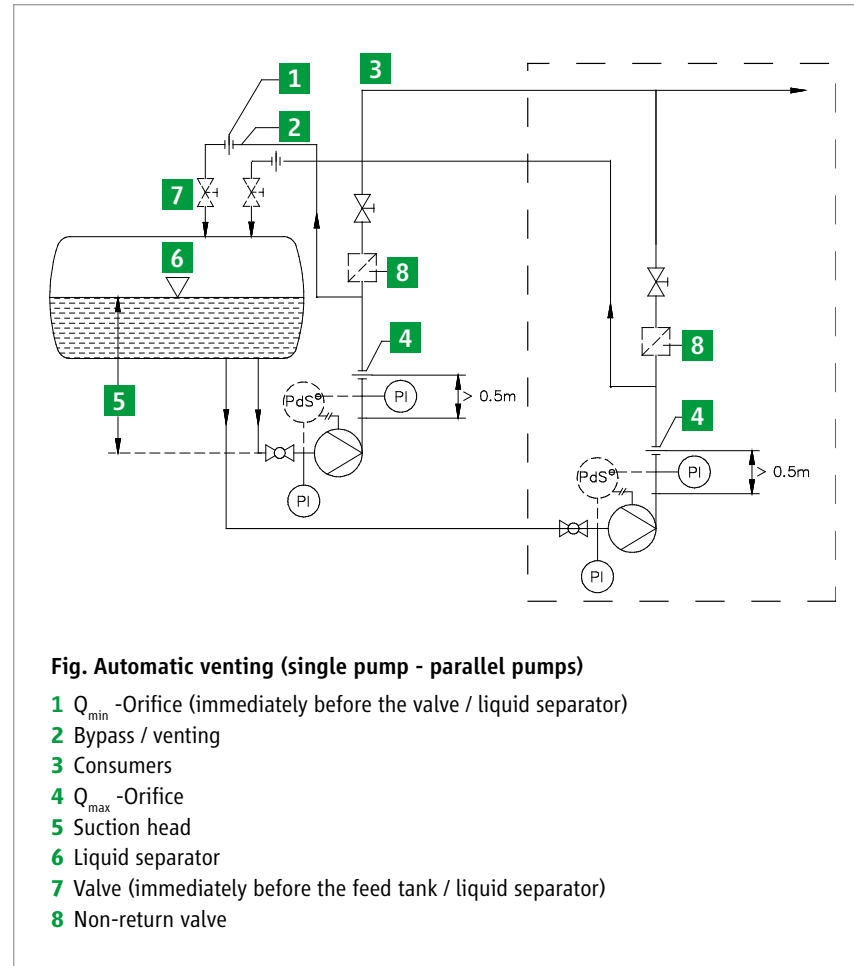

- Table of Contents
- General information
- Function
- Operating principle
- Characteristic maps
- Versions
- CAM 1 / CAM 2
- CAMR 2
- CAM 3
- Documentation and tests
- Installation**
- Protection and monitoring
- Flow regulation
- Design software
- Contact



## Orifice and inducer

---

### Orifice

We recommend protecting the HERMETIC pumps by using two orifices against any outside influence (for example by operating personnel). Orifice 1 ( $Q_{\min}$ ) ensures the minimum throughput required to dissipate the motor heat loss. Orifice 2 ( $Q_{\max}$ ) maintains the minimum differential pressure in the rotor space that is needed to stabilise the hydraulic axial thrust balancing and to prevent the evaporation of the partial flow. A flow regulator can be used instead of the  $Q_{\max}$  orifice.

### Inducer

Inducers are axial impellers that are arranged on the same shaft immediately in front of the first impeller of a centrifugal pump to generate an additional static pressure in front of the blade cascade of the impeller. Inducers are primarily used where the energy level provided by the system is insufficient ( $NPSHA > NPSHR$ ). The HERMETIC inducer reduces the NPSHR value of the pump by approx. 0.5 m over the entire characteristic curve. In many cases, inducers are also used prophylactically if the expected resistance of the inlet or suction line cannot be accurately determined or if fluctuations in NPSHA are expected due to changes in the geodetic height of the inlet liquid level or its pressure superimposition. Inducers are also particularly suitable for conveying boiling liquids (that are afflicted with gas bubbles). In both cases, the inducer can be used to prevent cavitation or reduced output provided it is correctly calculated and matches the flow rate of the impeller it feeds.

Table of Contents

General information

Function

Operating principle

Characteristic maps

Versions

CAM 1 / CAM 2

CAMR 2

CAM 3

Documentation and tests

Installation

**Protection and monitoring**

Flow regulation

Design software

Contact





## Flow regulator

### General information

The flow regulator was specially developed for refrigerant systems. This type of valve allows the safe operation of pumps in a range normally not possible for pumps with  $Q_{max}$  orifice. The adjacent graph shows the added operating range obtained by using a flow regulator instead of a  $Q_{max}$  orifice. Often, a smaller, less expensive pump can be used.

### Operation

The flow regulator must be filled with liquid during operation. The operation of the valve depends on the material data of the pumped medium. When ordering the valve, it is therefore important that complete information on the characteristics of the pumped medium in the operating range to be regulated is available. The density of the pumped medium is the most important characteristic for the correct design of a valve.

### Maintenance

The flow regulator requires no regular maintenance or readjustment. The valve inserts can be reordered if necessary.

### Area of application

The flow regulator is mounted on the discharge branch of the pump. The flow regulator limits the maximum flow rate of the pump. However, in contrast to the  $Q_{max}$  orifice, the flow rate  $< Q_{max}$  is almost equal to the full delivery pressure of the pump behind the valve. The flow regulator regulates the delivery rate to ensure that the maximum pump capacity is not exceeded. This protects the pump from overload and keeps the delivery rate within the optimum NPSH range of the pump.

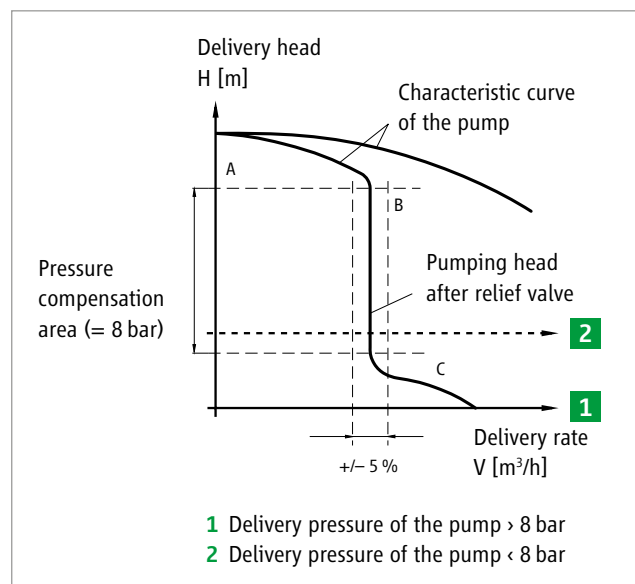

Table of Contents

General information

Function

Operating principle

Characteristic maps

Versions

CAM 1 / CAM 2

CAMR 2

CAM 3

Documentation and tests

Installation

Protection and monitoring

**Flow regulation**

Design software

Contact



## Flow regulator

### Working principle

The flow restriction is achieved by specially shaped openings in a spring-loaded, movable piston. The pressure difference in front of and behind the piston moves it. This ensures that only the appropriate amount flows through the openings. It follows that with increasing pressure difference, the spring is compressed. This means that the specially shaped openings are only partially released. When the pressure difference in front of and behind the valve decreases, the spring pushes the piston back in line with the changing pressure difference releasing a larger part of the opening. If the pressure difference exceeds the specified maximum value (pressure compensation range, generally 8 bar), the spring is compressed up to the stop, and the valve then works like a fixed orifice. The same applies when the required minimum pressure is not reached.

#### Functional schematic of the valve

##### Position A

In position A, the insert works as an orifice. As a result, little pressure is relieved at the valve.

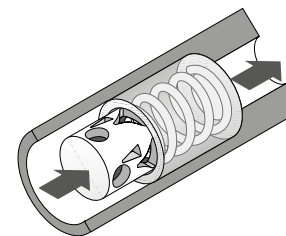

##### Position B

In the pressure compensation range, the insert limits the maximum volumetric flow rate as a function of the differential pressure with an accuracy of  $\pm 5\%$ .

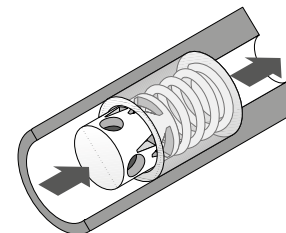

##### Position C

Behind the pressure compensation area, the insert is completely compressed and acts as an orifice.

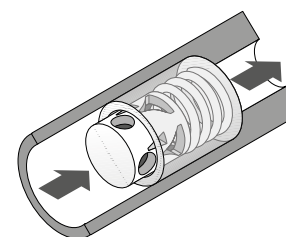

Table of Contents

General information

Function

Operating principle

Characteristic maps

Versions

CAM 1 / CAM 2

CAMR 2

CAM 3

Documentation and tests

Installation

Protection and monitoring

**Flow regulation**

Design software

Contact

